

Lubricate all seals with clean hydraulic oil prior to assembly.
DO NOT USE SILICONE BASED LUBRICANTS.

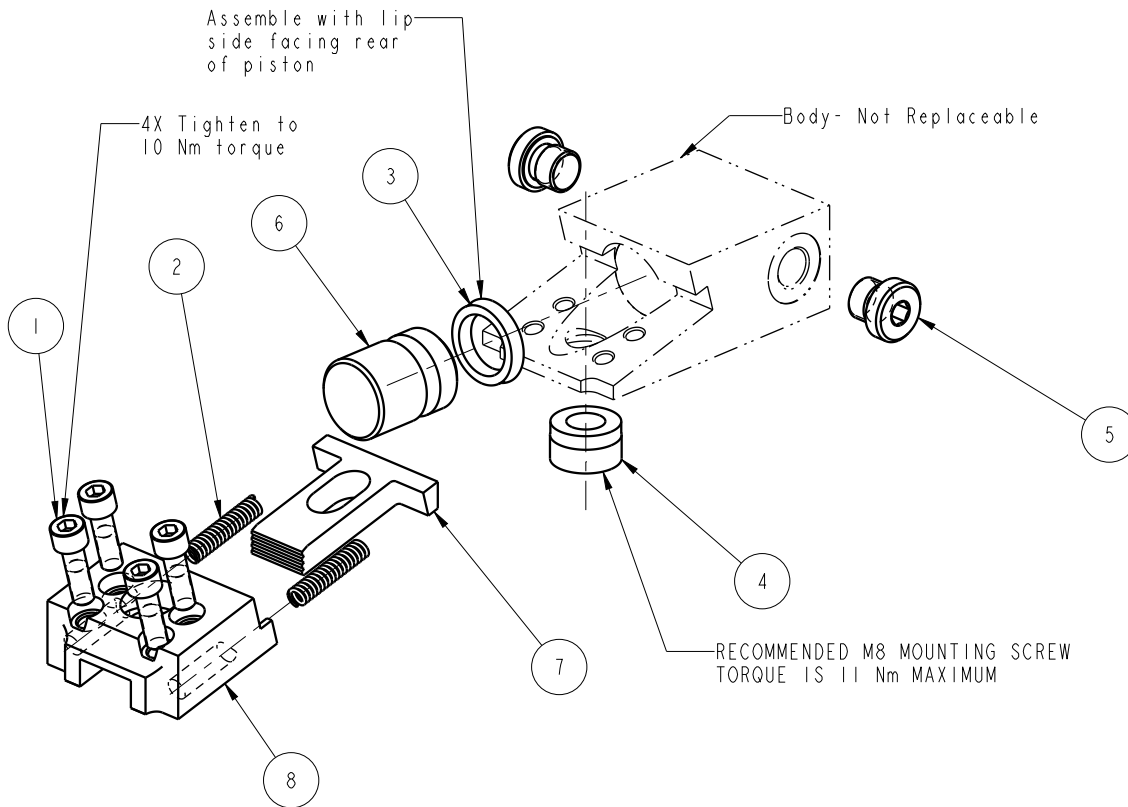

NO	QTY	PART NO	DESCRIPTION	REPAIR KIT	REPAIR KIT (FKM)
1	4	21410028	SCREW, CAP, SOCH, 10-32 X 5/8, ALY		
2	2	23310011	SPRING, COMPRESSION	X	X
3	1	39010013	SEAL, BEVEL, 9/16 X 3/32 X 3/4	X	39012000
4	1	41540800	PIVOT, EC, METRIC		
5	2	43068004	PLUG, SOCH, G1/8		
6	1	81510800	PISTON, EDGE CLAMP, 2000		
7	1	81530800	BLADE, EDGE CLAMP, 2000		
8	1	81530801	CAP, EDGE CLAMP, 2000		
N/A	N/A	62153002	KIT, REPAIR	NOTED	N/A
N/A	N/A	62153003	KIT, REPAIR, FKM	N/A	NOTED

PARTS LIST



VEKTEK, INC.
1334 E. SIXTH AVE. P.O. BOX 625
EMPORIA, KS. 66801 U.S.A.

ASSEMBLIES AFFECTED
41-5310-01

PARTS LIST, ASSY, EDGE CLAMP, 9 KN

SIZE
A MPL1513

REV
K

K	2943	RELEASE	JDW	11/12/15
REV	IN ACCORDANCE WITH ECN	EFFECTIVE DATE	REVISED BY	DATE
DRW BY:	BUSH	DRAWING STATUS: Released		
DATE:	12/13/94	PRODUCTION APPROVED FOR RELEASED STATUS ONLY		

FORM FEG035_PL_ASIZE, REV. B

SHEET 1 OF 1